

COUPLING ELEMENTS

built-in and threaded body designs, nominal diameters 3/5/8/12

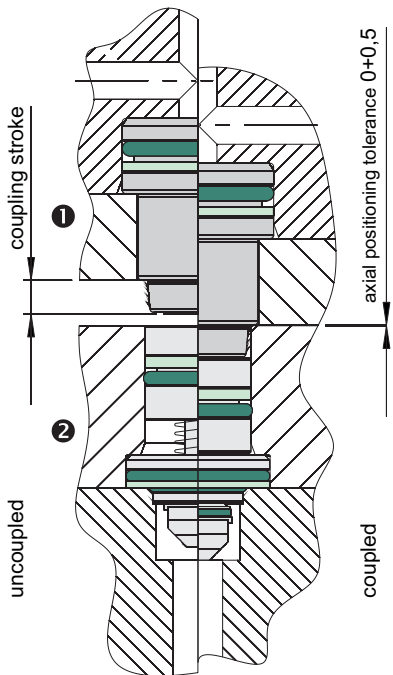

- ① Coupling nipple
- ② Coupling mechanism

Operating conditions:

Coupling nipple and coupling mechanism must face coaxially each other before the coupling process.

The base plates of both elements must be guided about 2 to 3 mm before contact of the sealing surfaces within the radial positioning tolerance.

The coupling force between coupling nipple and coupling mechanism resulting from hydraulic pressure according to the formula has to be compensated positively from the outside.

The axially acting front seal areas must be protected from contamination. Good results can be achieved by rinsing and following blowing-off with compressed air.

The sealing of the mechanism is done in the drill base of the mounting hole. The required surface quality in the drawing has to be kept.

Technical data:

Nominal diameter:	3	5	8	12
Operating pressure max. [bar]	350	500	300	250
Flow max./minute [l]	8	12	25	50
Coupling stroke [mm]	4,5	4,5	7,0	10,0
Coupling force min. at 0 bar [N]	94	98	98	169
Axial coupling force pressurized per coupling position	$F[N]=9,4xp[bar]$	$F[N]=15,4xp[bar]$	$F[N]=31,4xp[bar]$	$F[N]=70,7xp[bar]$
Axial positioning tolerance [mm]	+ 0,5	+ 0,5	+ 0,5	+ 0,5
Radial positioning tolerance [mm]	± 0,3	± 0,3	± 0,3	± 0,5
Permitted angle tolerance	± 1°	± 1°	± 1°	± 1°



Coupling force:

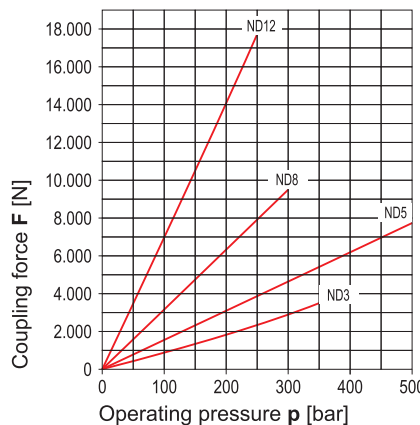

Operating pressure p [bar]

- ND 3 = F [N] = 9,4 x p [bar]
- ND 5 = F [N] = 15,4 x p [bar]
- ND 8 = F [N] = 31,4 x p [bar]
- ND 12 = F [N] = 70,7 x p [bar]

Flow resistance:

Δp characteristic with HLP 22, viscosity 34 cst

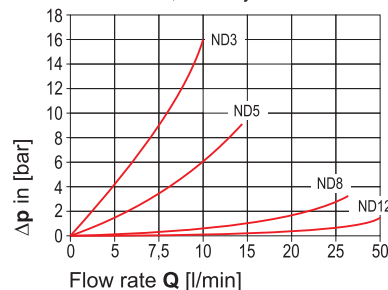

Flow rate Q [l/min]



Webcode: 010003

We also design and manufacture special designs

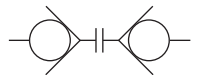

Description:

Coupling elements are used to prevent leakage when transmitting liquid or gaseous mediums or vacuum. The coupling elements are special compact parts, which can be installed directly into a receiving housing. The system seal (axial seal) between coupling mechanism and coupling nipple acts axially. It is placed in the coupling mechanism. This design makes it possible to have positioning tolerances.

Depending on the seal material the coupling elements are pressurized or depressurized coupleable. The built-in elements are particularly suitable for installation in plates of multiple coupling systems. Threaded body elements can be directly screwed into the fixture body, for example of a tool change system. There, they are ideal suitable as an interface for medium transfer.

Advantages:

- ☒ Space-saving installation in individual receiving housing possible
- ☒ Transmission of liquid and gaseous mediums and vacuum
- ☒ Pressurized or depressurized coupling
- ☒ Various with four nominal diameters
- ☒ Stainless materials and replaceable system seals for long service life

HYDROKOMP®
Hydraulische Komponenten GmbH

Siemensstraße 16, 35325 Mücke (Germany)
Phone: +49 6401 225999-0
Fax: +49 6401 225999-50
E-mail: info@hydrokomp.de
Internet: www.hydrokomp.de



Coupling elements / Coupling mechanisms

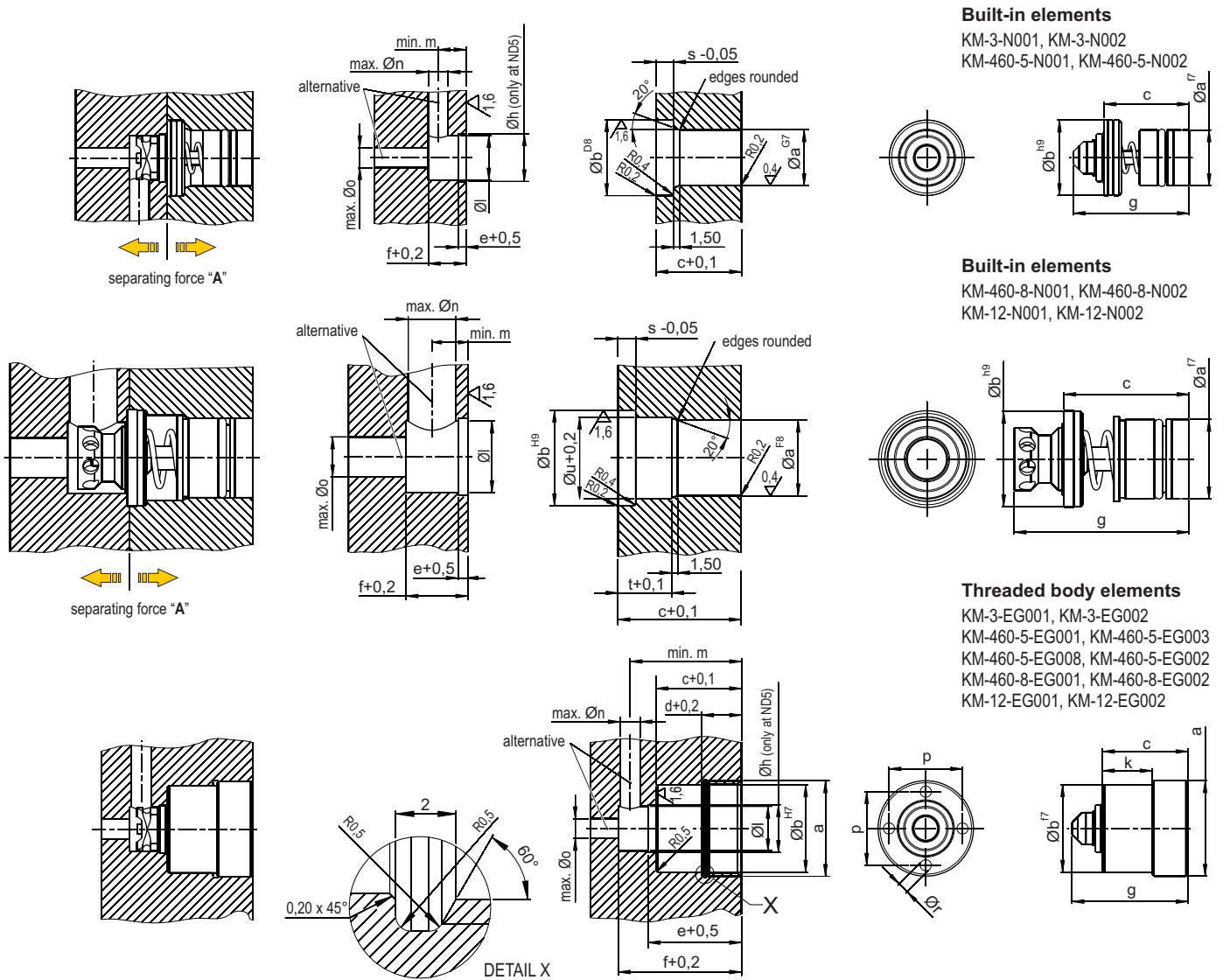

Built-in elements
 KM-3-N001, KM-3-N002
 KM-460-5-N001, KM-460-5-N002

Built-in elements
 KM-460-8-N001, KM-460-8-N002
 KM-12-N001, KM-12-N002

Threaded body elements
 KM-3-EG001, KM-3-EG002
 KM-460-5-EG001, KM-460-5-EG003
 KM-460-5-EG008, KM-460-5-EG002
 KM-460-8-EG001, KM-460-8-EG002
 KM-12-EG001, KM-12-EG002

Technical data:

Nominal diameter	3		5			8		12	
	built-in	thread. body	built-in	thread. body	thread. body	built-in	thread. body	built-in	thread. body
Separating force "A" [N]	15,4 x p [bar]	–	28,4 x p [bar]	–	–	45,2 x p [bar]	–	96,2 x p [bar]	–
Tightening torque [Nm]	–	15	–	20	25	–	32	–	41
a [mm]	11	M20x1,5	14	M24x1,5	M30x1,5	20	M36x1,5	30	M45x1,5
b [mm]	14	18	19	22	25	24	30	34,7	40
c [mm]	21,5	21,5	21,5	21,5	21,5	31	31	41	41
d [mm]	–	10	–	10	10	–	13	–	18
e [mm]	–	–	2	23,5	23,5	–	–	–	–
f [mm]	9,5	31	9,5	31	31	15,5	46,5	16,5	57,5
g [mm]	29	29	29	29	29	44	44	53,1	53,1
h +0,1 [mm]	–	–	12	12	12	–	–	–	–
k [mm]	–	13	–	12,5	12,5	–	19,5	–	24,6
l +0,1 [mm]	11,2	11,2	11,2	11,2	11,2	18	18	22	22
m [mm]	7	28	7	28	28	9	40	9	50
n [mm]	5	5	5	5	5	12	12	12	12
o [mm]	7	7	7	7	7	10	10	12	12
p [mm]	–	15,5	–	18,5	22	–	28	–	37
r [mm]	–	2x2,6	–	4x2,8	2x4,5	–	2x4,5	–	2x4,5
s [mm]	4,5	–	4,5	–	–	4,5	–	6	–
t [mm]	–	–	–	–	–	13,5	–	18,5	–
u [mm]	–	–	–	–	–	21,6	–	31,5	–
Order number:	KM-3...		KM-460-5...			KM-460-8...		KM-12...	
depressurized coupling	...-N001	...-EG001	...-N001	...-EG008	...-EG001	...-N001	...-EG001	...-N001	...-EG001
pressurized coupling	...-N002	...-EG002	...-N002	...-EG002	...-EG003	...-N002	...-EG002	...-N002	...-EG002
Screw-in tool ⁽¹⁾	–	9000-057	–	9000-007	–	–	9000-058	–	–
Mounting tool ⁽²⁾	9000-011	9000-011	9000-010	9000-010	9000-010	9000-013	9000-013	–	–
System seal, red ⁽³⁾	–	D-3-001	–	D-460-5-001	–	–	D-460-8-001	–	D-12-001
System seal, yellow ⁽³⁾	–	D-3-002	–	D-460-5-002	–	–	D-460-8-002	–	D-12-002

⁽¹⁾Accessories: for screwing the coupling mechanisms into the receiving housing (see page 4)

⁽²⁾Accessories: for the replacement of the system seal at coupling mechanisms (see page 4)

⁽³⁾Spare parts: System seal red = depressurized coupling, yellow = pressurized coupling, only for replacement orders, packing unit = 10 pieces



Coupling elements / Coupling nipples

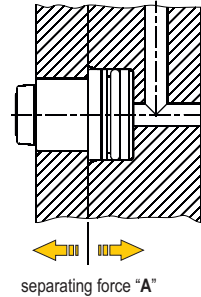
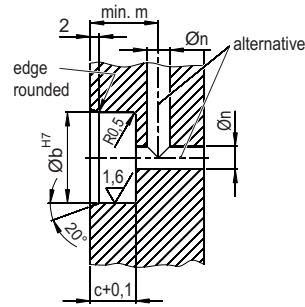
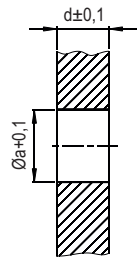
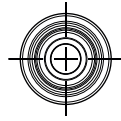
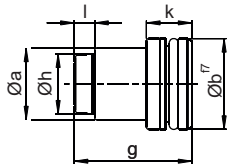

Built-in elements

KN-3-S001K, KN-3-S002K,
KN-460-5-S001L, KN-460-5-S003L,
KN-460-5-S001K, KN-460-5-S003K,
KN-460-8-S001, KN-460-8-S002,
KN-12-S001, KN-12-S002

Threaded body elements

KN-3-EG001, KN-3-EG002,
KN-460-5-EG001, KN-460-5-EG004,
KN-460-5-EG002, KN-460-5-EG003, KN-460-5-EG006,
KN-460-8-EG001, KN-460-8-EG002,
KN-12-EG001, KN-12-EG002

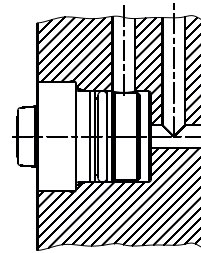
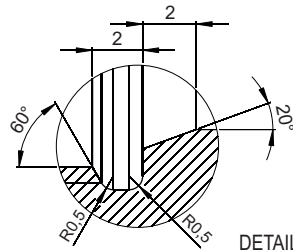
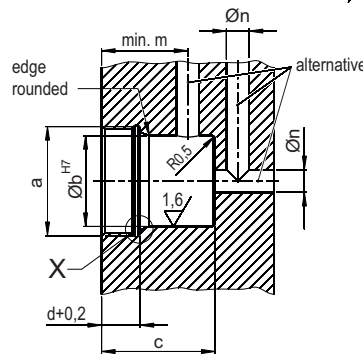
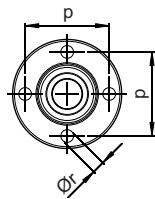
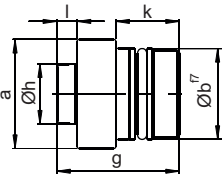

Technical data:

Nominal diameter	3		5					8		12	
	built-in	thread. body	built-in	built-in	thread. body	thread. body	thread. body ⁽⁴⁾	built-in	thread. body	built-in	thread. body
Separating force "A" [N]	20,1 x p [bar]		31,5 x p [bar]	31,5 x p [bar]	-	-	-	45,2 x p [bar]		96,2 x p [bar]	-
Tightening torque [Nm]	-	15	-	-	20	25	25	-	25	-	41
a [mm]	13	M20x1,5	16	16	M24x1,5	M28x1	M28x1	21	M30x1,5	31	M45x1,5
b H7 [mm]	16	16	20	20	20	20	20	24	25	35	35
c [mm]	10	23	10	16,5	25	25	34	9	26	12	32
d [mm]	11,4	8,4	11,4	17	8,5	8,5	8,5	15	8,5	15,4	13,4
g [mm]	25,9	25,9	26	38,1	27	27	37	31,4	29,9	37,4	40
h [mm]	9,8	9,8	13,5	13,5	13,5	13,5	13,5	18,5	18,5	28,5	28,5
k [mm]	10	13	10	16,5	14	14	19,5	9	14	12	16,6
l [mm]	4,5	4,5	4,5	4,5	4,5	4,5	4,5	7,4	7,4	10	10
m [mm]	15	19	15	22	19	19	19	15	22,5	21	31
n [mm]	5	5	5	5	5	5	5	10	10	12	12
p [mm]	-	15,5	-	-	18,5	20	20	-	24	-	37
r [mm]	-	2x2,6	-	-	4x2,8	2x4,2	2x4,2	-	4x3,5	-	2x4,5
Order number:	KN-3...		KN-460-5...					KN-460-8...		KN-12...	
depressurized coupling	...-S001K	...-EG001	...-S001K	...-S001L	...-EG003	...-EG004	...-EG006	...-S001	...-EG001	...-S001	...-EG001
pressurized coupling	...-S002K	...-EG002	...-S003K	...-S003L	...-EG002	...-EG001	-	...-S002	...-EG002	...-S002	...-EG002
Screw-in tool ⁽⁵⁾	-	9000-057	-	-	9000-007	9000-012	9000-012	-	9000-173	-	-

⁽⁴⁾This coupling nipple has a pressure relief function in the uncoupled state. It may only be installed into the tank line. There, it prevents a pressure build-up at any faulty piston seals. The opening pressure is approx. 3 - 5 bar.

⁽⁵⁾Accessories: for screwing the coupling nipples into the receiving housing (see page 4)

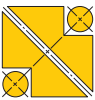

Mounting tools:

Coupling mechanisms of HYDROKOMP are designed in a way that the front system seal is replaceable.

The system seal wears in daily use by contamination and metal chips.

If the coupling mechanism itself does not show any damage, the system seal can be replaced separately.

Order numbers for mounting tools and system seals are listed on page 2.

For more information, see data sheet 100-5.

Webcode: 010005



Screw-in tools:

These tools are used to screw the coupling mechanisms and coupling nipples secure into the housing.

The screw-in tool can be tightened for example by a cordless powered screwdriver or wrench.

There are different screw-in tools for coupling mechanisms and coupling nipples available. They differ in their pin assignment and various nominal diameters.

Order numbers for screw-in tools see charts on page 2 and 3.



Applications:



Single coupling system with cleaning nozzle, (ND 5) depressurized coupling, housing according to customer's requirements

f.l. Coupling nipple plate:
coupling nipple threaded-body type

f.r. Coupling mechanism plate with cleaning nozzle: coupling mechanism built-in type



Single coupling system, (ND 3) depressurized coupling, housing according to customer's requirements

f.l. Coupling mechanism plate:
coupling mechanism threaded body type

f.r. Coupling nipple plate:
coupling nipple threaded body type



The built-in coupling elements are particularly suitable for installation in plates for multiple clamping systems (see data sheet 100-4).

In these systems different coupling elements can be combined. Also rotary couplings can be integrated as well as additional functions e.g. hydro mechanical locking and cleaning nozzle etc..